



COOLMOBILE C/CR

Mobile heating and air-conditioning units from THERMOBILE are the air-conditioning units for a wide range of applications. Easy to transport and ready for use. Our cooling units are specially designed for mobile use for outdoor installation. Coolmobile is compact and should be placed inside the tent. Air transport through flexible hoses.

Features

- Compact design
- Easy transport thanks to built-in transport rollers (8 kW and 17 kW) and forklift slots
- Heating/Cooling
- Recirculation or external air supply connections with flexible hoses

Applications

- Technology events
- Mobile field hospitals
- Shelter tents
- Other RDS systems

Working principle

With the Coolmobile, you can lower the temperature with approx. 12°C. For the season change the CR variant can also heat in an "operational reversal".

TECHNICAL SPECIFICATIONS | DIMENSIONS AND WEIGHTS

	C8	C17	CR17	CR34
Productnumber	56.007.150	56.017.150	56.017.050	56.034.050
Cooling capacity kW	8,2	17,0	17,0	32,8
Heating capacity kW	-	-	20,0	37,7
Cooling range	+10°C / +45°C	+10°C / +45°C	+10°C / +45°	+17°C / +45°
Heating range	-	-	From +7°C	From +7°C
Temperature Δ	±12°C	±12°C	±12°C	±12°C
Airflow	1.500 m ³ /hr	3.500 m ³ /hr	3.500 m ³ /hr	7.000 m ³ /hr
Connection	230V/1Ph/50Hz	400V/3Ph/50Hz	400V/3Ph/50Hz	400V/3Ph/50Hz
Power supply	13,0 A	13,7 A	13,7 A	27,5 A
Power consumption	3,3 kW/hr	5,5 kW/hr	5,5 kW/hr	11,0 kW/hr
Air inlet Ø	300 mm	500 mm	500 mm	2 x 500 mm
Air outlet Ø	300 mm	500 mm	500 mm	2 x 500 mm
Colour	White	White	White	White
Width	900 mm	1.200 mm	1.200 mm	1.200 mm
Length	1.700 mm	1.800 mm	1.800 mm	2.250 mm
Height	1.150 mm	1.400 mm	1.400 mm	2.050 mm
Weight	200 kg	305 kg	305 kg	600 kg

ACCESSORIES



Air transport hoses



Roomthermostat

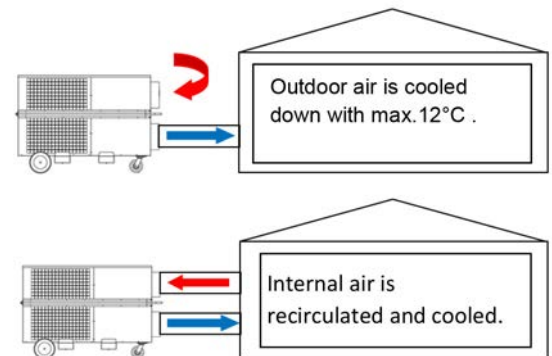

C = cooling only, CR = cooling and heating.

With recirculating air you do not only save energy costs, but will also significantly increase the effectiveness.

THERMOBILE INDUSTRIES BV



THERMOBILE

Thermobile Coolmobile CR MOBILE HEAT PUMP

Cooling only : C8 & C17
Cooling & heating : CR17 & CR34



Features :

- Compressors High Efficiency
- Able to withstand ambient temperature, cooling from 20°C to 45°C (R410A)
- Optional EC fan for Cooling from 10°C to 45°C
- Analogic Pressure Transducer
- Phase sequence relay protected against reversed phases for 3 phase models
- Room temperature sensor thermostat
- Low noise level

1- PRESENTATION AND OPERATION

This device is a mobile air conditioner for cooling demountable structures such as tents with a cooling capacity from 7 kW to 34 kW, depending of the model.

When the relative humidity of the air inlet is high, the air can be cooled below its dew point and humidity is then condensed to water. This process requires a certain amount of latent cooling but allows a dehumidification process, which is an important factor in comfort for the user.

The operating range is between 20 and 45 ° C and is controlled by the HP / LP pressure. The drop in air temperature depends on the conditions of entry (humidity).

The device are made with two compartment, isolated from each other. Its operation is based on a cooling circuit broken down by two groups motorcycle fans.

The side of the device on which connect the ducts contain the evaporator. The fan sucks the warm indoor air, cool this air through the exchanger and return it cold in the tent.

The opposite side contain the condenser. The fan draws in ambient outside air, it cross through the exchanger and returns it outward.

The cooling system is filled with refrigerant R410a. This circuit is completely waterproof and allows the unit to operate in areas with a maximum ambient temperature of +45 ° C.

At high ambient temperatures (above 45 ° C), the cooling of the condenser air flow is too low and a high pressure stops the HP switch. The pressure switches HP / BP will reset automatically after a few minutes.

At an ambient temperature below 20 ° C, moisture in the airflow can form ice on the evaporator. To avoid this, the pressure switch cuts the low pressure in the system. If the ambient temperature is too low, the BP activation causes frequent starting and stopping of the compressor. This process can damage the compressor and should be avoided by always using the product within the specified temperature range. See "Specifications".

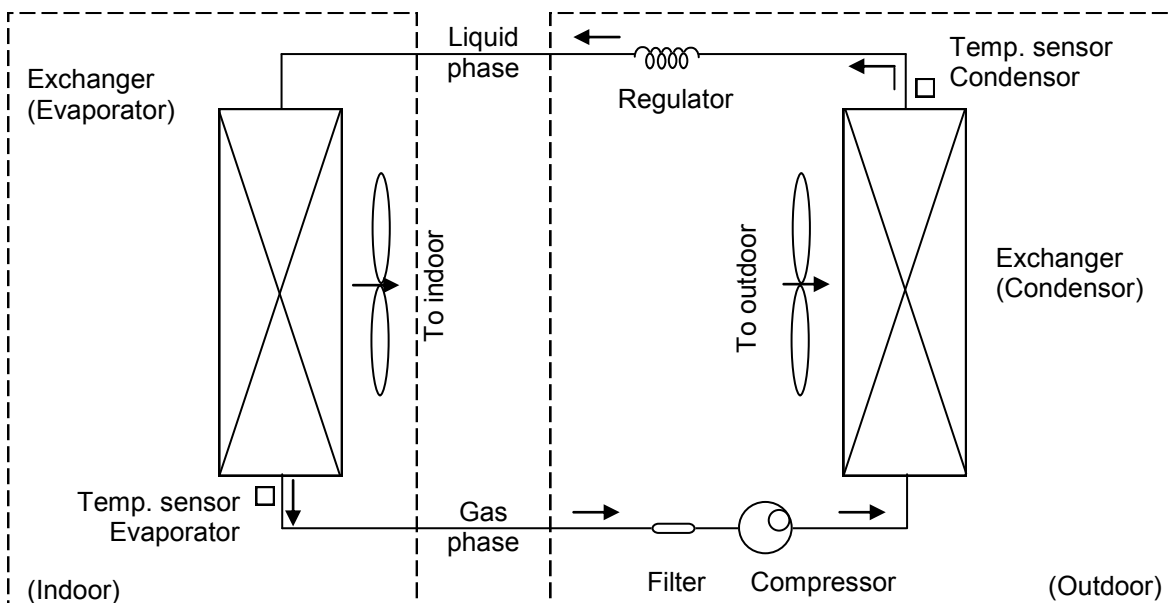

Compressor: Used to circulate the fluid in the cooling circuit

Filter: Absorbs moisture and impurities in the cooling circuit

Condenser: Sends the heat generated in the tent or room outwards

Regulator: Sends the amount of liquid that is right in the evaporator

Evaporator: Absorbs heat of the tent or room by cooling the air circulating

High pressure switch / BP: To ensure that the compressor does not work at a temperature too low or too high

2 GENERAL RULES FOR INSTALLATION

The installation configuration is an important factor in improving the performance and reliability of the air conditioner. There are different ways to place the devices, here we give you some important recommendations.

2-1 Ducts

CAUTION: The ducts used are the same diameter as the connections of units. The junction between the different lengths must be watertight. The total length of the circuit should not exceed 6 meters per circuit (return and supply). For longer length, please contact us.

Always use the least possible sheath. In general, think that every air duct 3m isolated changes the temperature inside the pipe by 5 ° C.

The sheaths result in a loss that's why we must always put straight, Fig.1. In case of deviation, avoiding significant bends (bends > 45 °), Fig.2, prefer them large curves, fig.3.

Fig.1

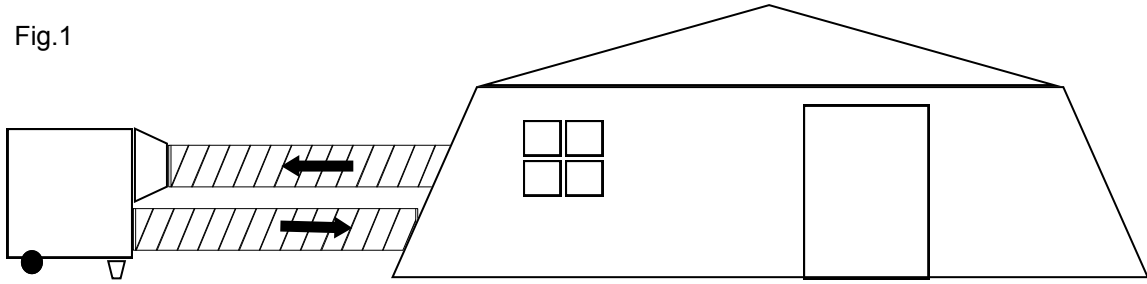

Fig.2

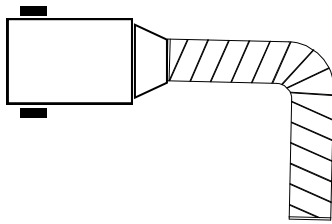
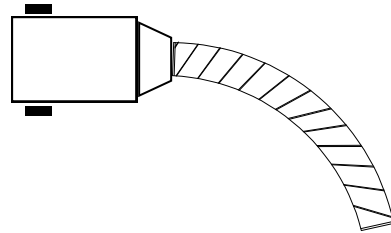

Fig.3



Place the air distribution duct cooled as close to the ceiling, the cold air will descend slowly to the ground and will be returned to the air conditioner through the air duct placed at the lowest, Fig.1.

2-2 Effect of the sun

The heating, due to solar effect reduces the efficiency of the air conditioner, heat builds up in the ducts and in the tents it's greenhouse effect. We recommend installing a sunshade to cover the air conditioning, ducts and the tent. It also becomes more effective if using panels/insulated coatings in the tent.

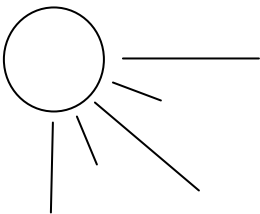
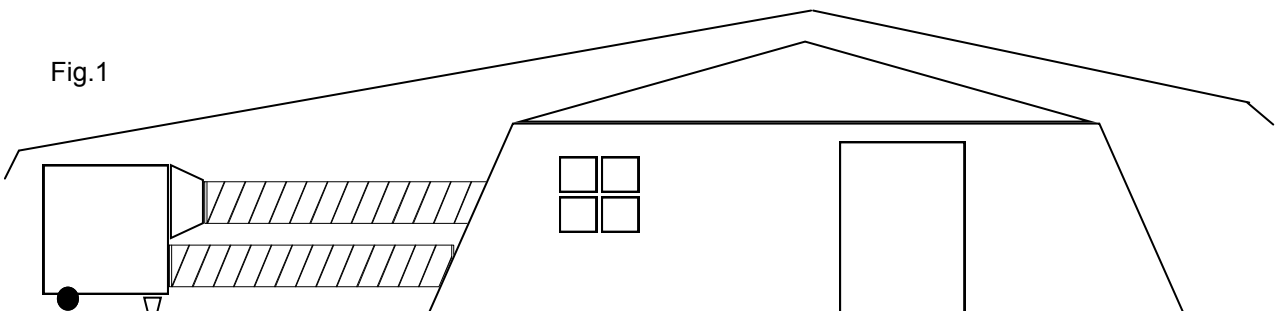

Fig.1



2-3 Airflow

To cool the air effectively, the air sent to the air conditioner must be the lowest possible. If the ambient temperature is lower than outside temperature, it is more efficient to re-circulate the air from the tent. To do this, connect the insulated ducts for blowing and sucking of air, between the tent and the air conditioner, fig.4.

If the temperature inside the tent is higher than the outside temperature, it may be advantageous to use the device without air intake duct, fig.5. Attention in this case you risk introducing dust or increase pressure in the tent.

Fig.4

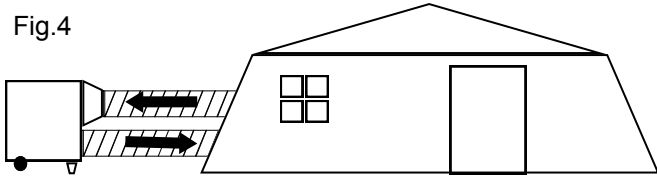
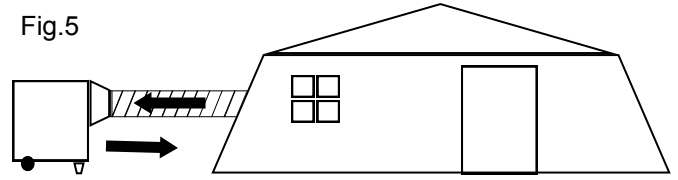

Fig.5



2-4 Various

- Keep doors and openings of the tent/room closed when using the air conditioner.
- Avoid all heat generating sources in the air conditioned room.
- Do not cover, fig.6, or obstruct the rear of the air conditioner, fig.7. Keep a free and clear area for a good air circulation allowing the correct operation of the conditioner, fig.8 & 9.
- If the air does not circulate well, the unit switches to safety. Poor repeated use causes irreversible damage.

Fig.6

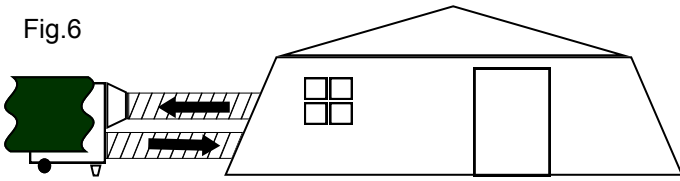

Fig.7

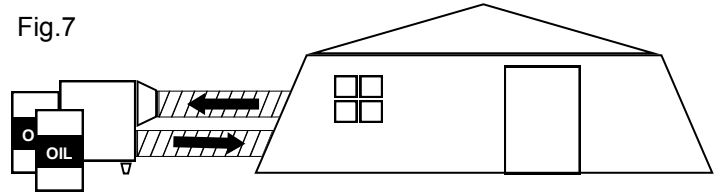

Fig.8

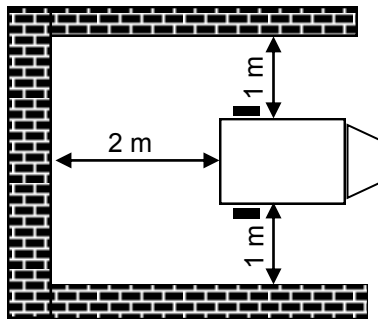
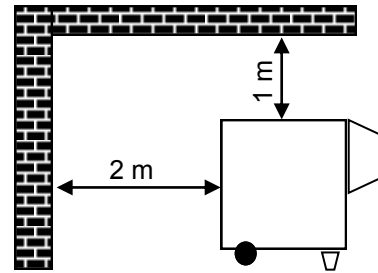

Fig.9



- Always ensure that the exhaust ducts, fig.10, or air intake, fig.11, is not blocked or obstructed even partially. If the air circulation is prevented the unit switches to safety. Poor repeated use causes irreversible damage.

Fig.10

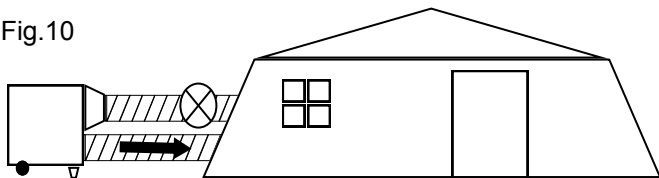
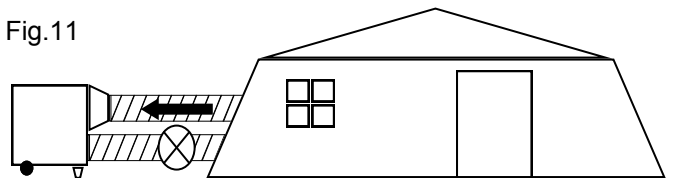

Fig.11



- Accumulation of water produced by condensation, fig.12, disrupt the use of the air conditioner, so we recommend that you raise the unit on a pallet for example, or to evacuate the condensate to a remote area of the air conditioner.

Fig.12



CARACTÉRISTIQUES TECHNIQUES / TECHNICAL SPECIFICATIONS

Nominal ton			2,2	4,8	4,8	9,5	
Model			C8	C17	CR17	CR34	
Capacity Cooling mode*	Cooling Capacity	Btu/h	28 000	58 000	58 000	111 000	
		W	8 200	17 000	17 000	32 800	
Capacity Heating mode*	Heating Capacity	Btu/h	-	-	58 000	111 000	
		W	-	-	20 000	32 800	
Electrical data	Power supply	V-PH-Hz	230-1-50	380-3-50	380-3-50	380-3-50	
	Rated power Input	W	3 300	5 500	5 500	13 000	
Performance	Air Circulation (High speed)	m3/h	1 500	4 500	4 500	7000	
	Indoor external static pressure	Pa	100	100	100	100	
Indoor Coil	Number of rows		3	3	3	3	
	Fin spacing	mm	2,3	2,3	2,3	2	
		inch	3/32	3/32	3/32	3/32	
	Special			Grooved Tube	Grooved Tube	Grooved Tube	Grooved Tube
				Louvered fins	Louvered fins	Louvered fins	Louvered fins
				hydrophilic aluminum fins	hydrophilic aluminum fins	hydrophilic aluminum fins	hydrophilic aluminum fins
Tube diameter	mm	Φ9.54	Φ9.54	Φ9.54	Φ9.54		
	inch	3/8	3/8	3/8	3/8		
Indoor fan	Type		Centrifugal Blower	Centrifugal Blower	Centrifugal Blower	Centrifugal Blower	
	No. used		1	1	1	2	
	Diameter	mm	Φ280mm	Φ355mm	Φ355mm	Φ355mm	
		inch	11	14	14	14	
	Drive type		DIRECT	DIRECT	DIRECT	DIRECT	
	No. motors		1	1	1	2	
	Motor output	W	240	315	315	315	
	Motor rpm	r/min	2600	1780	1780	1 780	
Compressor	Type		Rotary	Scroll	Scroll	Scroll	
	Quantity		1	1	1	1	
	Model		PA331X3CS	C-SBP205H38	C-SBP205H38	C-SCP400H38	
			-	-	-	-	
	Brand		GMCC	PANASONIC	PANASONIC	PANASONIC	
	Capacity	Btu/hr	28 000	58 000	58 000	111 000	
	Input	W	3 300	5 500	5 500	11 000	
	Rated current(RLA)	A	13	10,3	10,3	20	
Refrigerant oil charge	TYPE - mL	ESTER OIL VG74 - 1100	FV 68S - 1600	FV 68S - 1600	'		
Outdoor Coil	Number of rows		2	2	2	2	
	Fin spacing	mm	1,8	1,8	1,8	2	
		inch	0,0709	0,0709	0,0709	0,0709	
	Special			Grooved Tube	Grooved Tube	Grooved Tube	Grooved Tube
				Louvered fins	Louvered fins	Louvered fins	Louvered fins
				hydrophilic aluminum fins	hydrophilic aluminum fins	hydrophilic aluminum fins	hydrophilic aluminum fins
Tube diameter	mm	Φ9.54	Φ9.54	Φ9.54			
	inch	3/8	3/8	3/8	3/8		
Outdoor Fan	Type		Axial	Axial	Axial	Axial	
	No. used		1	1	1	1	
	Diameter	mm	Φ450	Φ630	Φ630	Φ800	
		inch	17,8	24,8	24,8	32	
	Drive type		Direct	Direct	Direct	Direct	
	No. motors		1	1	1	1	
	Motor model		ATE804S	ATE808S	ATE808S	ATE810AP	
	Motor output	W	420	520	520	1 250	
Motor rpm	r/min	1350	900	900	700		
Refrigerant	Type		R410A	R410A	R410A	R410A	
	Refrigerant volume	kg	2,1	3,6	3,6	7,2	
	Refrigerant Control		EEVX	EEVX	EEVX	EEVX	
Dimensions(W×H×D)	mm		900x1150x1700	1200x1400x1800	1200x1400x1800	1200x2050x2250	
	inch		35x45x67	47x55x71	47x55x71	47x81x88	
Net Weight	kg		200	305	305	600	
	lbs		386	672	672	1 322	

* The cooling capacity can change considerably depending on the humidity and air temperature.

** Optional EC Axial fan for cooling from 10°C instead of 20°C ambient temperature.

Dimensions C8

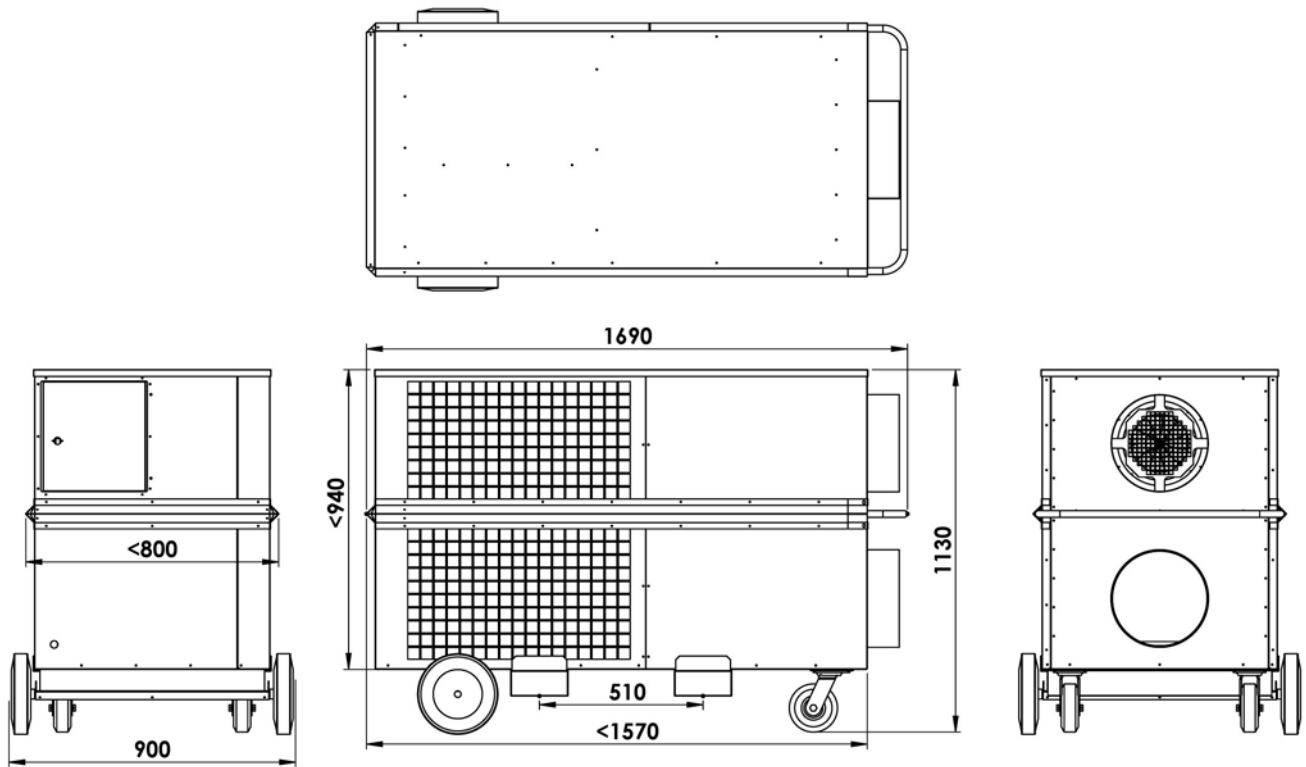

Dimensions C17 & CR17

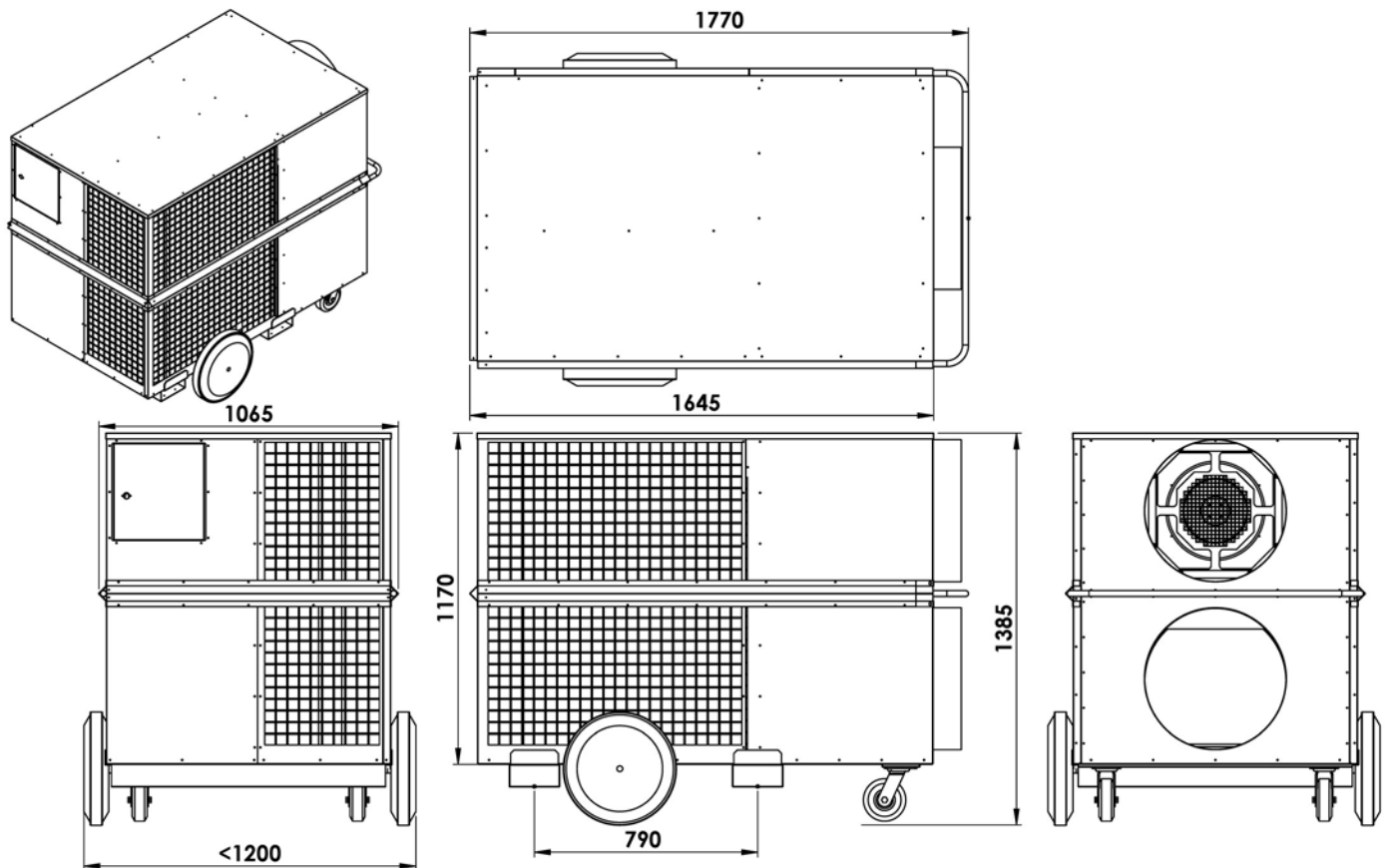

Dimensions CR34

